

## Technical Data Sheet

### TFACE S PIR

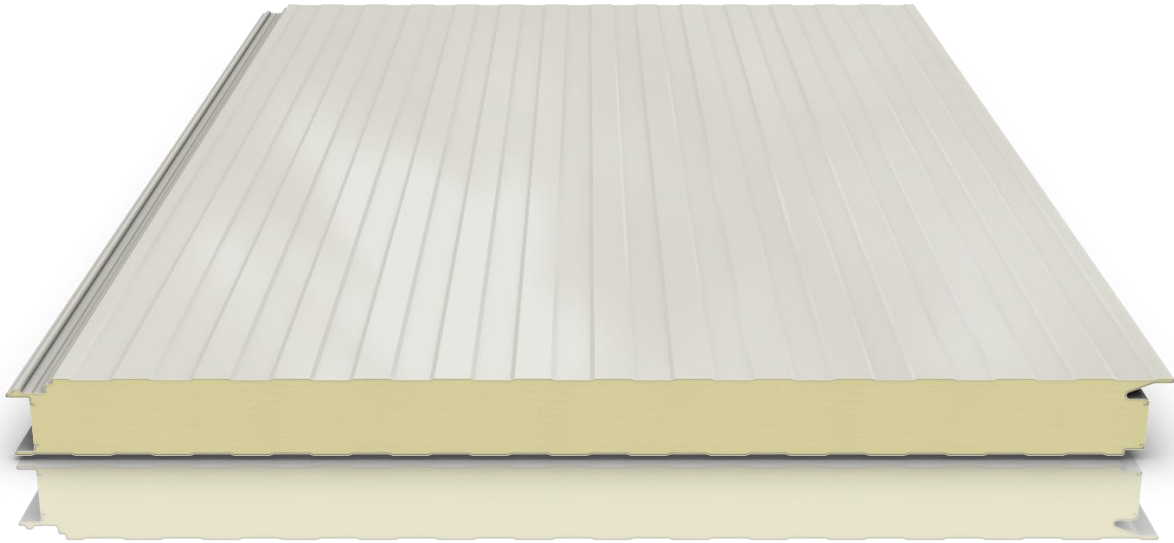

#### Description:

Facade sandwich panel, insulation core of polyisocyanurate and finishing outer and inner sheet of galvanized sheet. Suitable for both vertical and horizontal mounting. The various of profiles of the metal sheets and the lack of visible screws on the facade make them suitable for industrial and public buildings with modern design.

Manufactured according to BDS EN 14509:2013

density of the installation core: 40 kg/m<sup>3</sup> \*others on request

	external sheet	internal sheet
material	galvanized steel sheet, INOX, Aluminum	galvanized steel sheet, INOX, Aluminum
coating	PES, PVDF, Plastisol, Other special coating	
thickness	0.6 mm standard, other thickness on request	0.4 mm standard, other thickness on request

#### Geometry:

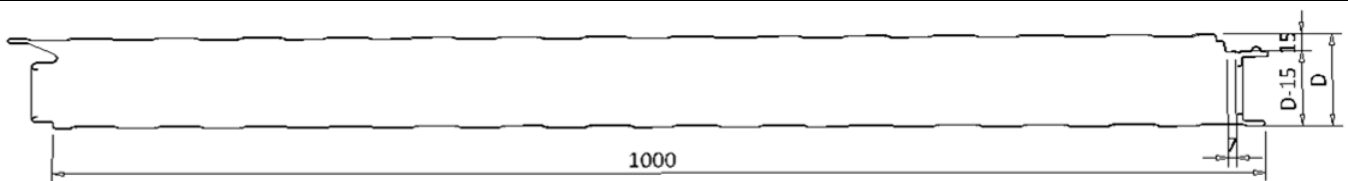

thicknesses	50, 60, 80, 100, 120, 150 mm
lengths	from 3000 to 16000 mm
covering width	1000 mm

#### Assembly:

The joint between the TFACE S façade panels is achieved through the double tongue - groove method.

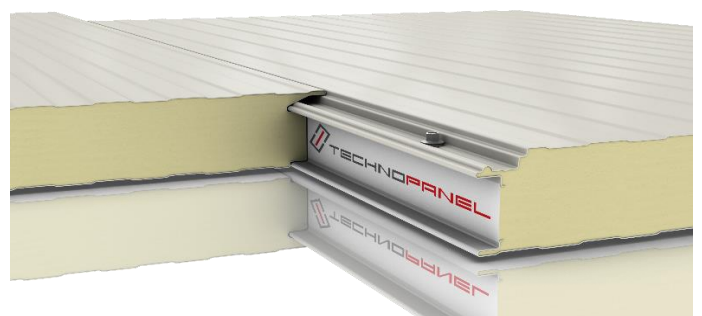
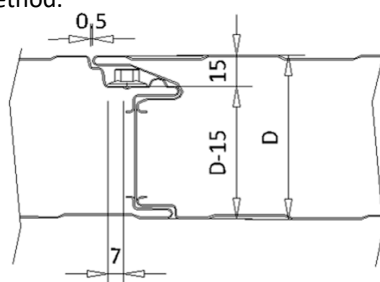

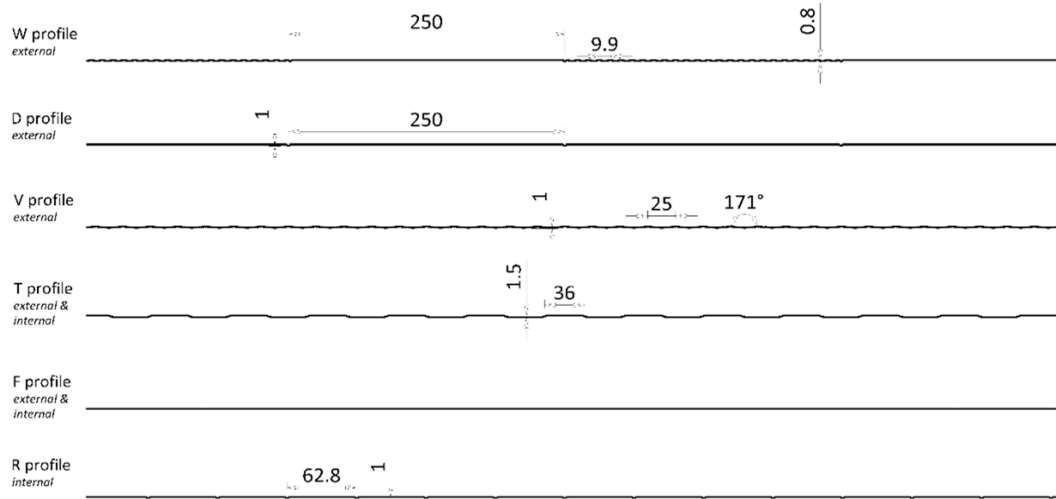
**Profile:**

**Weight and standard packing:**

D, mm	50	60	80	100	120	150
weight *with sheet metal 0.6/0.4, kg/m <sup>2</sup>	10,88	11,29	12,11	12,93	13,75	14,98
standard packing, pcs/package	22	18	14	11	9	7

**Thermotechnical characteristics:**

D, mm	50	60	80	100	120	150
thermal conductivity coefficient, W/mK	$\lambda = 0,022$ W/mK					
thermal transmittance coef. U, W/m <sup>2</sup> K	0,41	0,35	0,27	0,21	0,18	0,14
thermal transmittance coef. U <sub>d,S</sub> , W/m <sup>2</sup> K	0,54	0,43	0,29	0,23	0,19	0,15

\*U, W/m<sup>2</sup>K - coefficient of thermal transmittance regardless of joint types

\*U<sub>d,S</sub>, W/m<sup>2</sup>K - coefficient of thermal transmittance with consideration of the types of joints according to p.A.10.4 of BDS EN 14509:2013

**Fire resistance and reaction to fire:**

D, mm	50	60	80	100	120	150
class of reaction to fire	B-s1, d0					
fire resistance, min				EI30	EI30	EI30

**Size of self - tapping screw with washer V 16/2.0**

D, mm	50	60	80	100	120	150
min recommended length, mm	70	80	100	120	140	170

**Allowable Loads kN/m<sup>2</sup>:**

Дебелина на панела: Panel thickness:	Статическа схема / Static scheme:					
	L = 3,0m	L = 4,0m	L = 5,0m	L = 6,0m	L = 7,0m	L = 8,0m
TFACE PIR 50 0,5/0,4	2,24	1,75	1,14	0,66	0,41	0,26
TFACE PIR 60 0,5/0,4	2,69	2,02	1,44	0,90	0,56	0,37
TFACE PIR 80 0,5/0,4	3,58	2,56	1,71	1,13	0,71	0,47
TFACE PIR 100 0,5/0,4	4,48	3,10	1,98	1,37	0,86	0,58
TFACE PIR 120 0,5/0,4	5,11	3,39	2,13	1,48	1,09	0,81
TFACE PIR 140 0,5/0,4	5,74	3,58	2,29	1,59	1,17	0,90
TFACE PIR 150 0,5/0,4	6,06	3,70	2,37	1,65	1,21	0,93
TFACE PIR 160 0,5/0,4	6,37	3,81	2,44	1,70	1,24	0,95
TFACE PIR 180 0,5/0,4	7,00	4,05	2,60	1,80	1,32	1,01
TFACE PIR 200 0,5/0,4	7,64	4,29	2,75	1,91	1,40	1,07

Дебелина на панела: Panel thickness:	Статическа схема / Static scheme:					
						
	L = 3,0m	L = 4,0m	L = 5,0m	L = 6,0m	L = 7,0m	L = 8,0m
TFACE PIR 50 0,5/0,4	1,79	1,34	1,08	0,97	0,66	0,50
TFACE PIR 60 0,5/0,4	2,16	1,62	1,29	1,07	0,80	0,61
TFACE PIR 80 0,5/0,4	2,88	2,17	1,70	1,27	0,93	0,72
TFACE PIR 100 0,5/0,4	3,61	2,70	2,12	1,47	1,07	0,82
TFACE PIR 120 0,5/0,4	4,17	3,12	2,46	1,81	1,33	1,02
TFACE PIR 140 0,5/0,4	4,74	3,55	2,81	2,16	1,59	1,22
TFACE PIR 150 0,5/0,4	5,03	3,76	2,99	2,34	1,72	1,32
TFACE PIR 160 0,5/0,4	5,31	3,97	3,16	2,51	1,85	1,42
TFACE PIR 180 0,5/0,4	5,88	4,40	3,51	2,86	2,11	1,62
TFACE PIR 200 0,5/0,4	6,45	4,83	3,86	3,21	2,38	1,82

Дебелина на панела: Panel thickness:	Статическа схема / Static scheme:			
				
	L = 3,0m	L = 4,0m	L = 5,0m	L = 6,0m
TFACE PIR 50 0,5/0,4	1,86	1,40	1,11	0,94
TFACE PIR 60 0,5/0,4	2,24	1,68	1,34	1,12
TFACE PIR 80 0,5/0,4	2,99	2,24	1,76	1,47
TFACE PIR 100 0,5/0,4	3,74	2,80	2,23	1,82
TFACE PIR 120 0,5/0,4	4,33	3,24	2,58	2,05
TFACE PIR 140 0,5/0,4	4,92	3,68	2,94	2,28
TFACE PIR 150 0,5/0,4	5,22	3,91	3,12	2,40
TFACE PIR 160 0,5/0,4	5,51	4,13	3,29	2,51
TFACE PIR 180 0,5/0,4	6,10	4,57	3,65	2,74
TFACE PIR 200 0,5/0,4	6,70	5,02	4,01	2,98

**Notes:**

- \*The specified values are obtained on the basis of experimental tests from accredited laboratory and according the procedures described in standard EN14509
- \*Values in red color indicate loads for which the deflection limit  $f_u=L/100$  is reached.
- \*Values in blue color indicate loads obtained from shear work.
- \*The values of the allowable additional loads refer to panels installed under specified static systems and uniformly distributed load simulating respectively at roof panels - from snow, for facade panels - wind load.
- \*The values in the tables do not take into consideration the thermal effect. In cases where a detailed check is needed, as well as in cases different from those described in the load capacity tables, it is necessary to contact the Technopanel's Engineering Department.
- \*Construction calculations are the responsibility of the designer.
- \*The specified values in the tables are indicative, which need to be confirmed with calculations by the designer.
- \*The width of the supports of the sandwich panel construction shouldn't be less than 60mm.

**Main recommendations and details:**

- Cutting tools must ensure a clear and easy cut, without damages to the panel surface. Fine-tooth jigsaws are considered most suitable for cutting purposes. Circular saws can only be used, if they can provide accurate and clear cut. Angle grinders equipped with cutting discs are not suitable due to the overheating and formation of surface rust.

- During installation, special attention shall be paid to the air tightness of joints. No air gap shall be left in the vertical joint between two adjacent panels.

- For the panels' installation, the use of self-tapping screws with a washer is recommended. The type of screws shall depend on the thickness of the panel and the supporting structure. The minimum recommended length of the screw is indicated in the table above "Size of self-tapping screw with washer V 16/2.0", and the length of the drill is determined according to the thickness of the structure - for installation in steel from 1.5 mm to 5 mm - drill 6 mm, for installation in steel from 4 mm to 12 mm - drill bit 12 mm. In order to ensure adequate attachment of the panel to the structure, it is essential to keep the screws perpendicular to the panel surface while driving them into the panel.

- Detail Vertical Joint

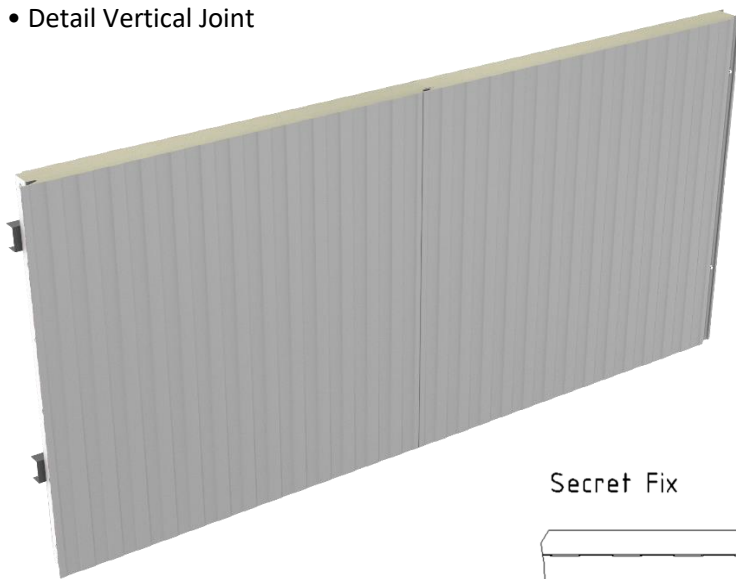

Legend:

- 1.1 - Wall Sandwich Panel
- 4.1 - Self tapping screw
- 6 - Structure

Secret Fix

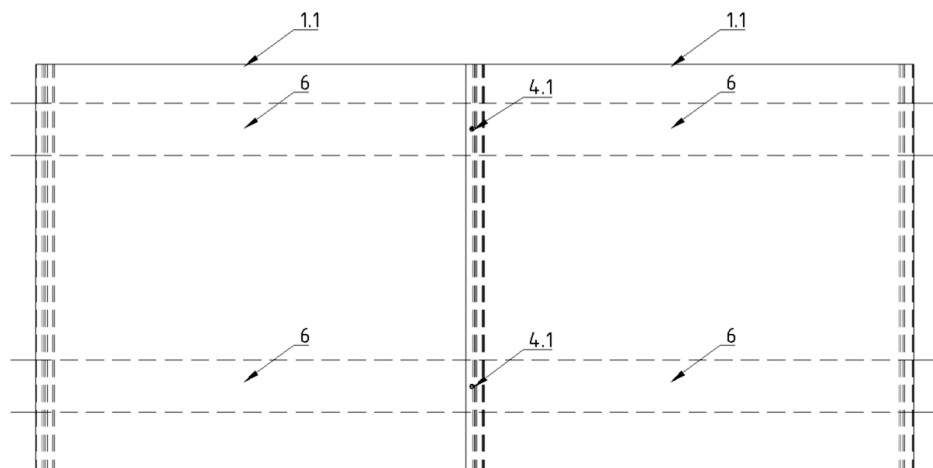
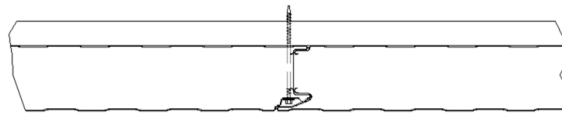

• Detail Horizontal Joint

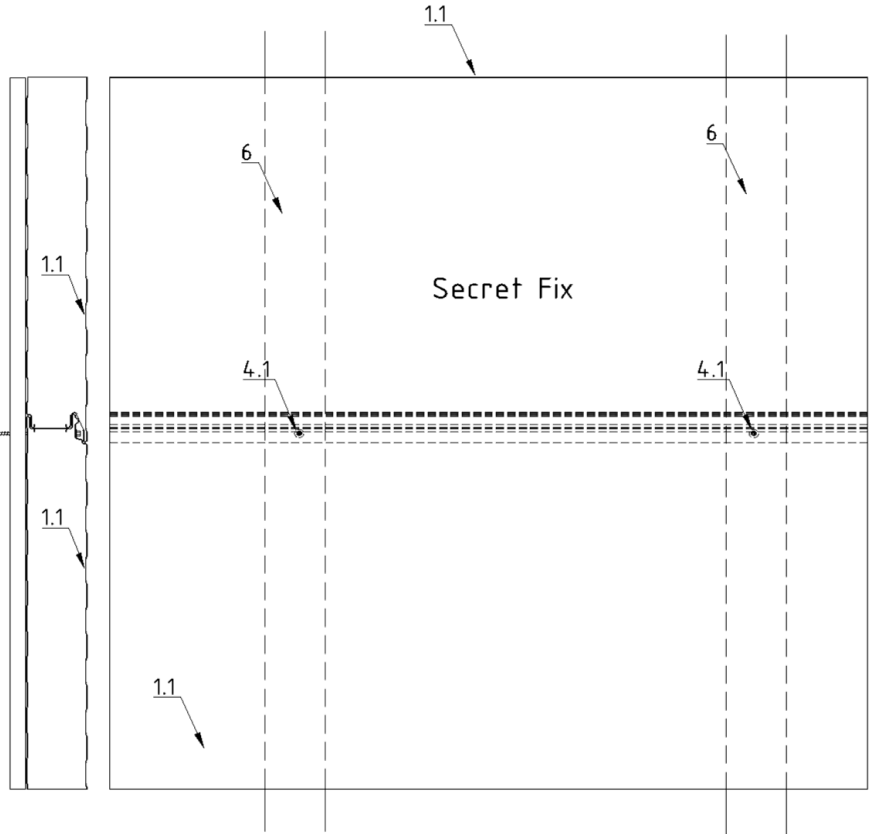
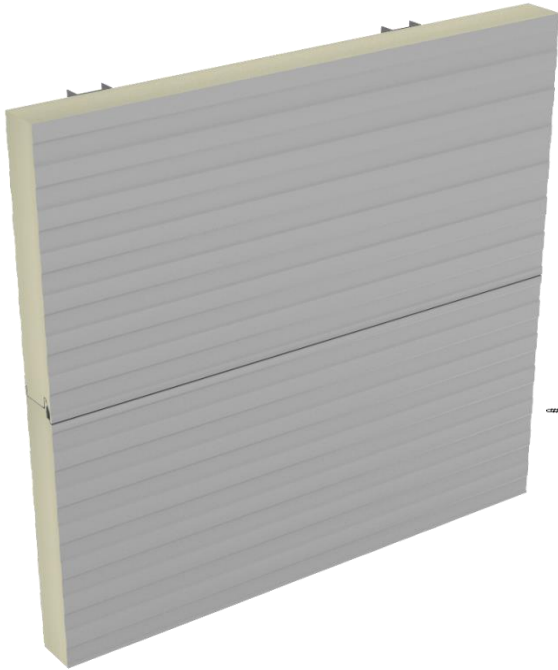

- Легенда:
- 1.1 - Wall Sandwich Panel
  - 4.1 - Self tapping screw
  - 6 - Structure

• Standard Detail Sill

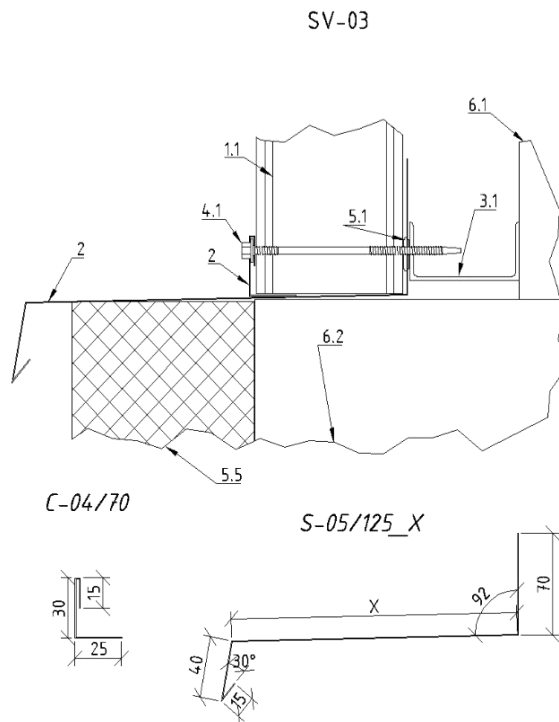
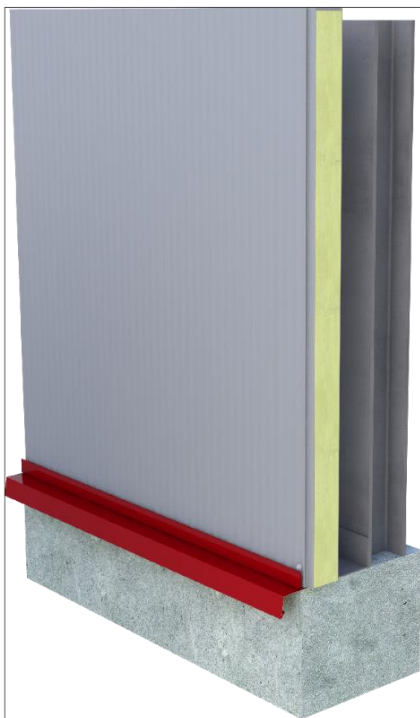

Legend:

- 1.1 - Wall Sandwich Panel
- 2 - Flashing
- 3.1 - U profile
- 4.1 - Self tapping screw
- 5.1 - Butyl tape
- 5.5 - Insulation
- 6.1 - Steel structure
- 6.2 - Reinforced concrete structure

• Standard Detail Extension Joint

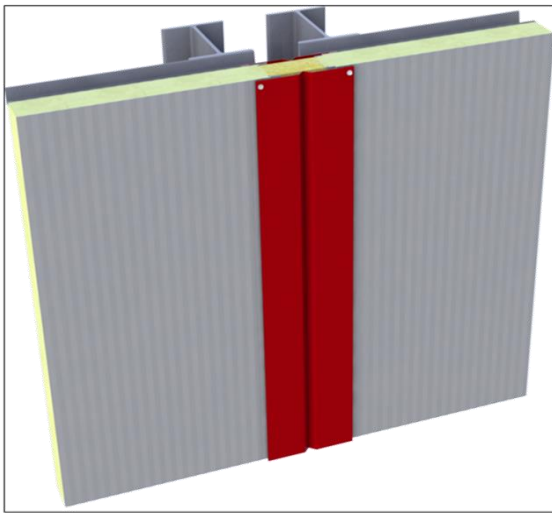

EVH-01

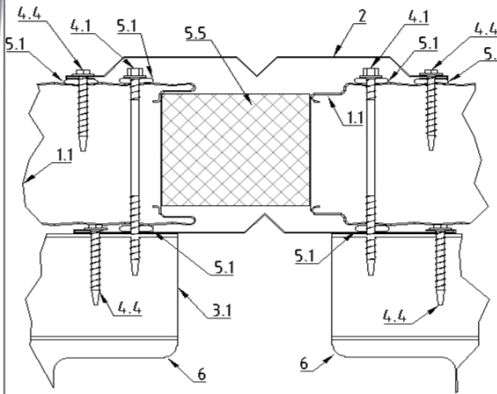

Legend:

- 1.1 - Wall Sandwich Panel
- 2 - Flashing
- 3.1 - U profile
- 4.1 - Self tapping screw
- 4.4 - Screw
- 5.1 - Butyl tape
- 5.5 - Insulation
- 6 - Structure

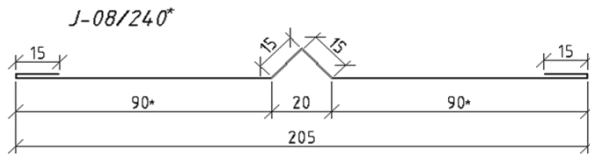
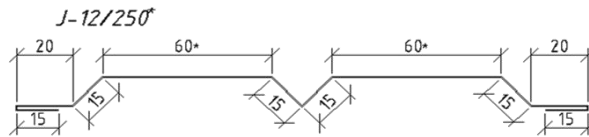

*\*When the flashing is used as a fire joint, the size is increased by 120mm*

• Standard Detail External Corner

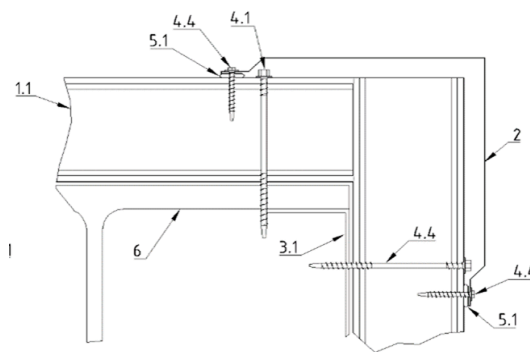
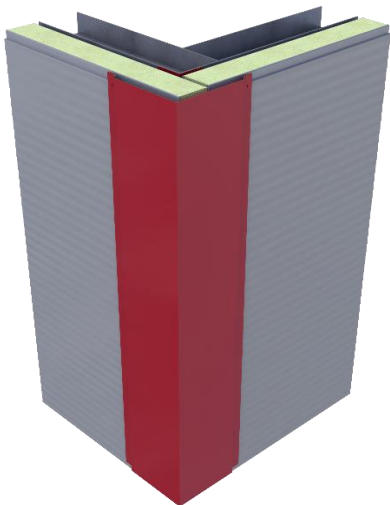

Legend:

- 1.1 - Wall Sandwich Panel
- 2 - Flashing
- 3.1 - U profile
- 4.1 - Self tapping screw
- 4.4 - Screw
- 5.1 - Butyl tape
- 5.5 - Insulation
- 6 - Structure

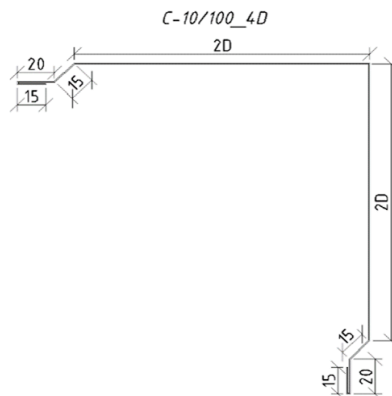

• Standard detail window - top, sides and bottom

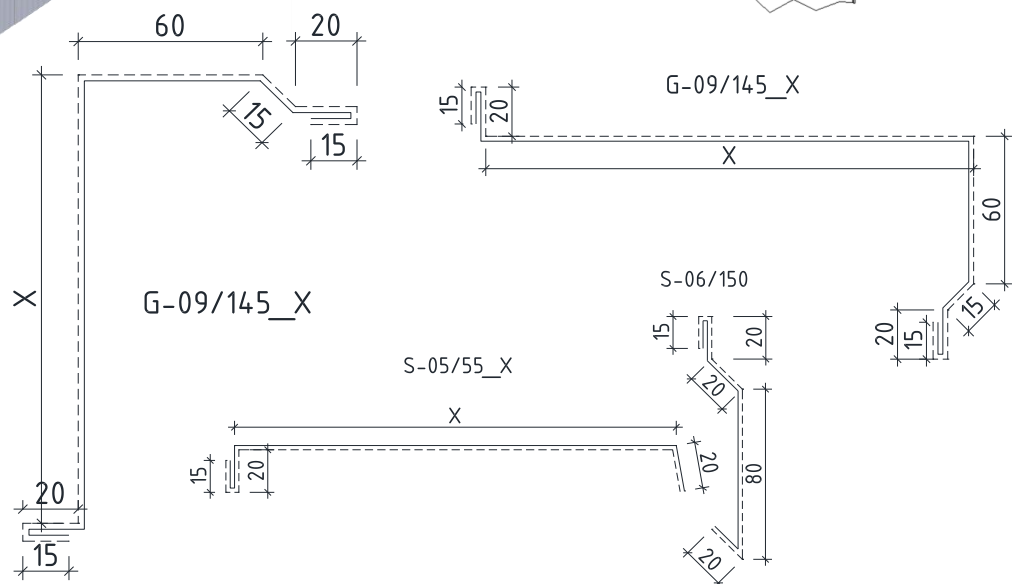
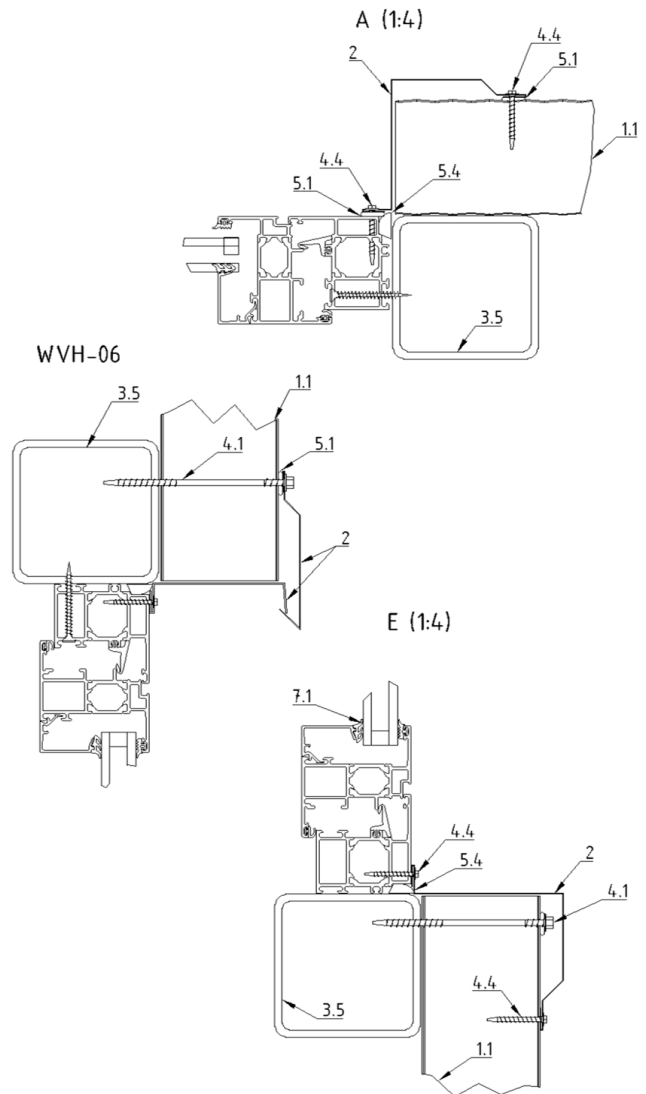

**Legend:**

- 1.1 - Wall Sandwich Panel
- 2 - Flashing
- 3.5 - □ profile
- 4.1 - Self tapping screw

- 5.1 - Butyl tape
- 5.4 - Silicone gasket
- 7.1 - Window



4.4 - Screw

- Standard Detail Door



DRV-01 (1:4)

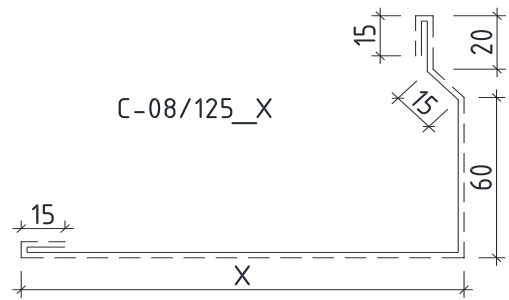
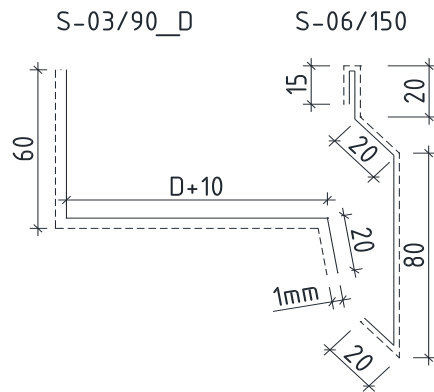
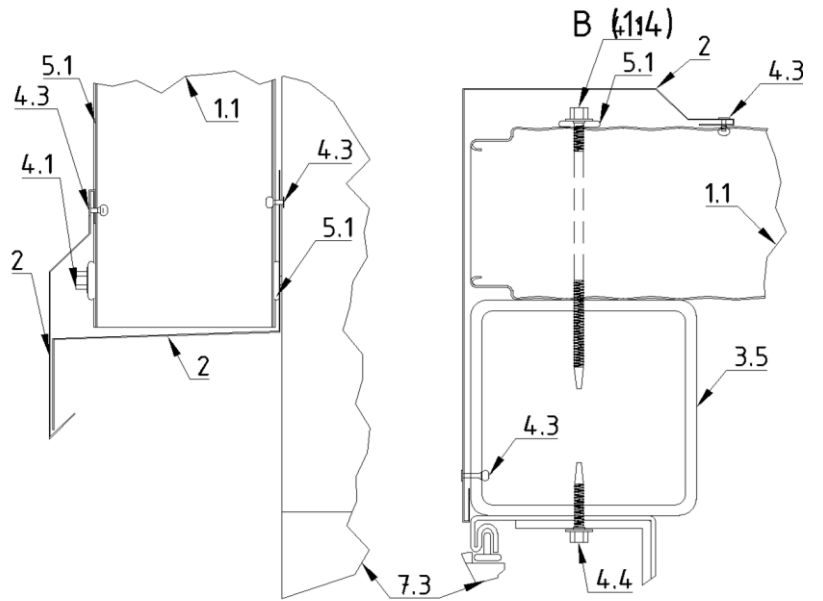

**Legend:**

- |                           |                           |
|---------------------------|---------------------------|
| 1.1 - Wall Sandwich Panel | 4.3 - Rivet               |
| 2 - Flashing              | 4.4 - Screw               |
| 3.5 - □ profile           | 5.1 - Butyl tape          |
| 4.1 - Self tapping screw  | 7.3 - Roller shutter door |



• Standard color range for TFACE S PIR

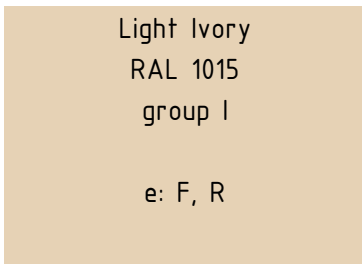
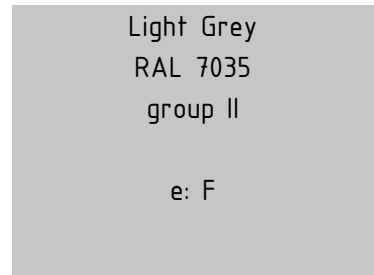
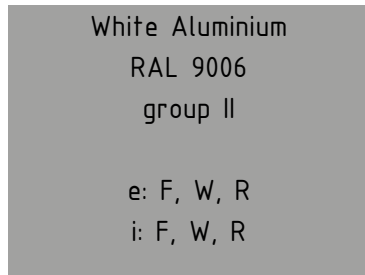
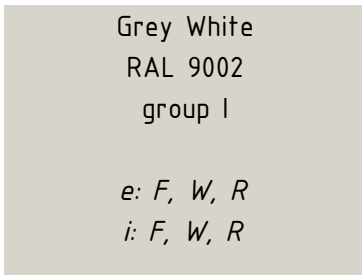

Legend: e: outer metal sheet      F: TFACE S facade panels      R: TTOP roof panels  
i: inner metal sheet      W: TFACE T wall panels

- The described colours should be interpreted as approximate.
- No guarantee for identical color shades on partial or additional
- In order to avoid nuance differences, complete information should be provided when ordering.
- Larger shade differences are possible with PVDF coatings.
- Additional panels in reserve should be calculated when ordering specific colours.
- Large temperature differences may occur between the internal and the sun exposed external sheet of the sandwich panels. As a result of the high coefficient of thermal expansion of the sheet, bending and tension stresses can be obtained in the cross-section of the panels. Special attention should be paid in this direction for colours of II and III colour group, and particularly for sandwich panels with PIR insulation core.